

# SICUREZZA SUL LAVORO

SAFETY AT WORK

Tutti gli articoli sono stati progettati per una durata illimitata nel tempo, seguendo scrupolosamente le normative italiane e internazionali in vigore con una particolare attenzione alla funzionalità e alla scelta dei materiali.

*All the articles have been designed for an unlimited duration in the time, following the Italian and international regulations in force with particular attention to functionality and at the choice of materials.*



R 290 30



R 290 31

# Normative in materia di tutela della salute e sicurezza sullavoro

## REGULATIONS CONCERNING THE PROTECTION OF HEALTH AND SAFETY AT WORK

UNI EN 15154

ANSI Z358.1

DIN 12899-3

- Per garantire ai lavoratori le migliori condizioni di sicurezza all'interno dell'area di lavoro le norme prevedono che vi siano installate apparecchiature collegate in modo permanente alla rete idrica che permettono un lavaggio rapido del corpo e degli occhi, l'erogazione deve essere mantenuta per un minimo di 15 minuti lasciando libere le mani.
- Le norme prevedono espressamente che quando i lavoratori stanno manipolando acidi, caustici o altri materiali particolarmente nocivi, gli apparecchi di emergenza devono essere posti nelle immediate vicinanze del pericolo.
- La normativa italiana prevede che il fungo doccia deve avere una capacità di erogazione di almeno 100 litri/minuto che corrispondono alla classe 3 prevista dallo standard tedesco. ANSI Z358.1 prescrive che a mm. 1500 dal suolo il diametro del cono di acqua deve essere di almeno mm. 500
- Le fontanelle lavaocchi devono avere una portata di liquido di lavaggio aerato non minore di 6 litri/minuto
- La rete di alimentazione deve assicurare una pressione di esercizio da 2 a 5 bar e le zone in cui sono installati gli apparecchi di emergenza devono essere opportunamente illuminate.
- La temperatura dell'acqua al fine di consentire un impiego agevole deve essere compresa da 20°C a 35°C. A questo scopo deve essere previsto un idoneo impianto di riscaldamento dell'acqua.
- Gli apparecchi di emergenza ove non presidiati devono essere dotati di sistemi di allarme che consentono di determinare quando le unità di emergenza vengono attivate.
- **È molto importante controllare periodicamente il funzionamento delle docce e dei lavaocchi anche per evitare la proliferazione di batteri nell'acqua ferma da molto tempo.**
- Il calcare dell'acqua causa incrostazioni che compromettono il corretto funzionamento degli apparecchi d'emergenza. È consigliato installare filtri adeguati sulla tubazione principale di alimentazione.
- *To guarantee workers the best security conditions inside the work area the rules provide for the installation of equipment permanently connected to the water supply network that allow a quick washing of the body and the eyes, the water supply must be maintained for a minimum of 15 minutes leaving both hands free.*
- *The rules expressly provide that when workers are handling acids, caustics or other particularly harmful materials, emergency devices must be placed in the immediate vicinity of the danger.*
- *The Italian legislation requires that the shower head must have a water supply capacity of at least 100 liters/minute corresponding to class 3 required by German standards.*  
*ANSI Z358.1 prescribes that to mm. 1500 from the ground the diameter of the water cone must be at least mm.500*
- *The eyewash fountains must have a liquid flow rate of aerated washing not less than 6 liters minute.*
- *The water supply network must ensure an operating pressure of from 2 to 5 bar and the areas in which the emergency luminaires are installed must be properly illuminated.*
- *The water temperature in order to allow an easy use must be between 20°C and 35°C. For this purpose a suitable water heating system must be provided.*
- *The unattended emergency equipment must be equipped with alarm systems that allow you to determine when emergency units are activated.*
- ***It is very important to check periodically the operation of the showers and eyewash also to avoid the proliferation of bacteria in the water.***
- *The limestone of the water causes encrustations that compromise the correct functioning of the emergency devices. It is recommended to install suitable filters on the main supply pipe.*

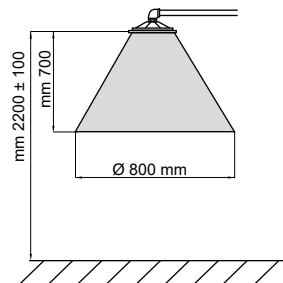



Trasmittitore autonomo di allarme IP65  
*Autonomous alarm transmitter IP65*



Ricevitore wireless luminoso/sonoro  
*Luminous/acoustic wireless receiver*



Push in alluminio pressofuso  
*Push in die-cast aluminium*

R290 10  
**LAVAOCCHI  
A PAVIMENTO  
CON APERTURA  
A SPINTA**  
*FLOOR-MOUNTED EYEWASH  
WITH PUSH OPENING*

RE 103 290  
**TRASMETTITORE  
E RICEVITORE  
WIRELESS  
DI ALLARME**  
*WIRELESS ALARM  
TRANSMITTER AND RECEIVER*

# LAVAOCCHI A PAVIMENTO VASCHETTA IN ABS CON APERTURA A PEDALE E A SPINTA

FLOOR-MOUNTED  
EYEWASH ABS BOWL  
WITH PEDAL AND  
PUSH OPENING



Push in alluminio pressofuso

*Push in die-cast aluminium*

R290 20/2

# LAVAOCCHI A PAVIMENTO VASCHETTA IN ACCIAIO INOX AISI 304

FLOOR-MOUNTED  
EYEWASH  
IN STAINLESS  
STEEL AISI 304



Push in alluminio pressofuso  
Push in die-cast aluminium

R290 54/2

# LAVACOCCHI A PAVIMENTO IN ACCIAIO INOX AISI 304

*FLOOR-MOUNTED  
EYEWASH  
IN STAINLESS  
STEEL AISI 304*



R290 54/6

**LAVAOCCHI A PAVIMENTO Ø 1/2" SCARICO Ø 1"1/4**

**FLOOR MOUNTED EYEWASH FEEDING Ø 1/2" OUTLET Ø 1" 1/4**

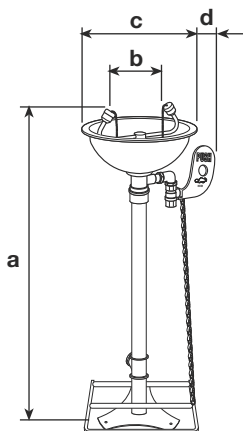
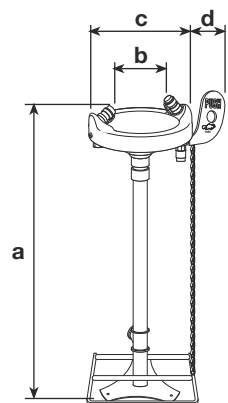
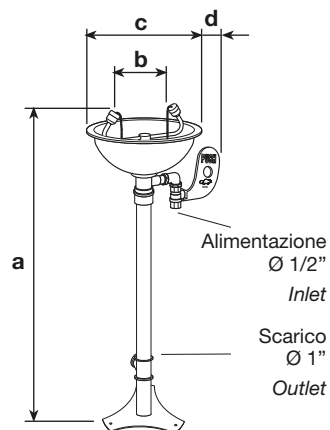
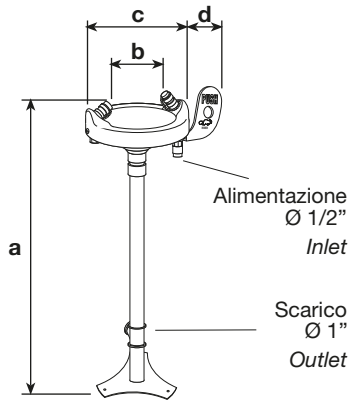

CODICE	mm a	mm b	mm c	mm d	NOTE
R290 10	1050	180	300	125	<p>Lavaocchi di colore verde con montaggio a pavimento, apertura a spinta, portata automatica 12 litri/min.</p> <p>■ <b>vaschetta lavaocchi ABS VERDE</b> ■ <b>PUSH in alluminio pressofuso</b></p> <p><i>Floor mounted eyewash, green colour, with push opening, automatic flow reducer 12 l/min.</i></p> <p>■ <b>eyewash bowl ABS GREEN</b> ■ <b>PUSH in die-cast aluminium</b></p>
R290 53	1100	175	300	100	<p>Lavaocchi di colore verde con montaggio a pavimento, apertura a spinta, portata automatica 12 litri/min.</p> <p>■ <b>vaschetta lavaocchi ACCIAIO INOX AISI 304</b> ■ <b>PUSH in alluminio pressofuso</b></p> <p><i>Floor mounted eyewash, green colour, with push opening, automatic flow reducer 12 l/min.</i></p> <p>■ <b>eyewash bowl STAINLESS STEEL AISI 304</b> ■ <b>PUSH in die-cast aluminium</b></p>
R290 12	1050	180	300	125	<p>Lavaocchi di colore verde con montaggio a pavimento con 2 comandi di apertura (a pedana e a spinta) portata automatica 12 litri/min.</p> <p>■ <b>vaschetta lavaocchi ABS VERDE</b> ■ <b>PUSH in alluminio pressofuso</b></p> <p><i>Floor mounted eyewash, green colour, with 2 opening controls (footboard/manual push), automatic flow reducer 12 l/min.</i></p> <p>■ <b>eyewash bowl ABS GREEN</b> ■ <b>PUSH in die-cast aluminium</b></p>
R290 54	1100	175	300	100	<p>Lavaocchi di colore verde con montaggio a pavimento con 2 comandi di apertura (a pedana e a spinta) portata automatica 12 litri/min.</p> <p>■ <b>vaschetta lavaocchi ACCIAIO INOX AISI 304</b> ■ <b>PUSH in alluminio pressofuso</b></p> <p><i>Floor mounted eyewash, green colour, with 2 opening controls (footboard/manual push), automatic flow reducer 12 l/min.</i></p> <p>■ <b>eyewash bowl STAINLESS STEEL AISI 304</b> ■ <b>PUSH in die-cast aluminium</b></p>

SICUREZZA SUL LAVORO – SAFETY AT WORK



dal 1980



MADE IN ITALY



**LAVAOCCHI A PAVIMENTO ALIMENTAZIONE Ø 1/2" SCARICO Ø 1"**  
**FLOOR MOUNTED EYEWASH FEEDING Ø 1/2" OUTLET Ø 1"**

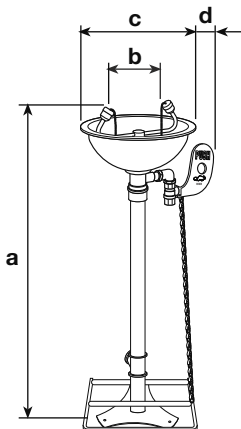
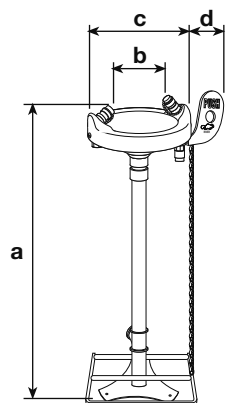
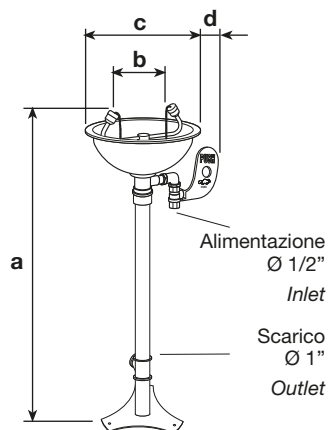
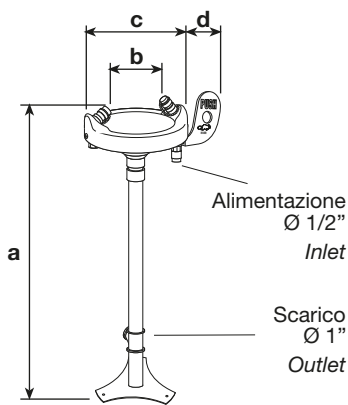

CODICE	mm a	mm b	mm c	mm d	NOTE
R290 20	1050	180	300	125	<p>Lavaocchi di colore giallo con montaggio a pavimento, apertura a spinta, portata automatica 12 litri/min.</p> <p>■ <b>vaschetta lavaocchi ABS GIALLO</b>                      ■ <b>PUSH in alluminio pressofuso</b></p> <p><i>Floor mounted eyewash, with push opening, automatic flow reducer 12 l/min.</i></p> <p>■ <b>eyewash bowl ABS YELLOW</b>                      ■ <b>PUSH in die-cast aluminium</b></p>
R290 53/2	1100	175	300	100	<p>Lavaocchi di colore giallo con montaggio a pavimento, apertura a spinta, portata automatica 12 litri/min.</p> <p>■ <b>vaschetta lavaocchi ACCIAIO INOX AISI 304</b>                      ■ <b>PUSH in alluminio pressofuso</b></p> <p><i>Floor mounted eyewash, with push opening, automatic flow reducer 12 l/min.</i></p> <p>■ <b>eyewash bowl STAINLESS STEEL AISI 304</b>                      ■ <b>PUSH in die-cast aluminium</b></p>
R290 20/2	1050	180	300	125	<p>Lavaocchi di colore giallo con montaggio a pavimento con 2 comandi di apertura (a pedana e a spinta) portata automatica 12 litri/min.</p> <p>■ <b>vaschetta lavaocchi ABS GIALLO</b>                      ■ <b>PUSH in alluminio pressofuso</b></p> <p><i>Floor mounted eyewash, with 2 opening controls (footboard/manual push), automatic flow reducer 12 l/min.</i></p> <p>■ <b>eyewash bowl ABS YELLOW</b>                      ■ <b>PUSH in die-cast aluminium</b></p>
R290 54/2	1100	175	300	100	<p>Lavaocchi di colore giallo con montaggio a pavimento con 2 comandi di apertura (a pedana e a spinta) portata automatica 12 litri/min.</p> <p>■ <b>vaschetta lavaocchi ACCIAIO INOX AISI 304</b>                      ■ <b>PUSH in alluminio pressofuso</b></p> <p><i>Floor mounted eyewash, with 2 opening controls (footboard/manual push), automatic flow reducer 12 l/min.</i></p> <p>■ <b>eyewash bowl STAINLESS STEEL AISI 304</b>                      ■ <b>PUSH in die-cast aluminium</b></p>



**LAVAOCCHI IN ACCIAIO INOX A PAVIMENTO ALIMENTAZIONE Ø 1/2" SCARICO Ø 1"**  
**FLOOR MOUNTED EYEWASH IN STAINLESS STEEL FEEDING Ø 1/2" OUTLET Ø 1"**

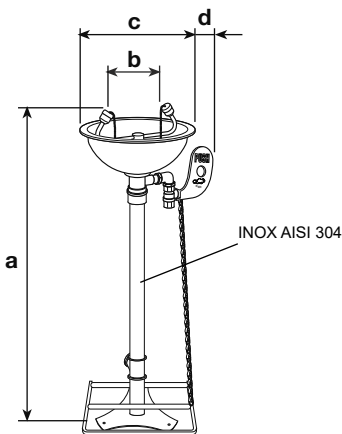
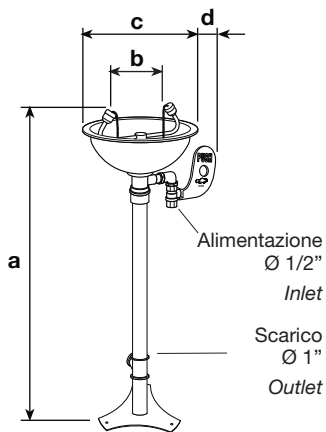

CODICE	mm a	mm b	mm c	mm d	NOTE
R290 53/5	1100	175	300	100	<p>Lavaocchi con montaggio a pavimento, apertura a spinta, portata automatica 12 litri/min.</p> <ul style="list-style-type: none"> <li>■ vaschetta lavaocchi ACCIAIO INOX AISI 304</li> <li>■ supporto ACCIAIO INOX AISI 304 per il montaggio a pavimento</li> <li>■ PUSH in alluminio pressofuso</li> </ul> <p><i>Pedestal mounted eyewash, with push opening, automatic flow reducer 12 l/min.</i></p> <ul style="list-style-type: none"> <li>■ eyewash bowl STAINLESS STEEL AISI 304</li> <li>■ support STAINLESS STEEL AISI 304 for floor mounting</li> <li>■ PUSH in die-cast aluminium</li> </ul>
R290 54/6	1100	175	300	100	<p>Lavaocchi con montaggio a pavimento con 2 comandi di apertura (a pedana e a spinta) portata automatica 12 litri/min.</p> <ul style="list-style-type: none"> <li>■ vaschetta lavaocchi ACCIAIO INOX AISI 304</li> <li>■ supporto ACCIAIO INOX AISI 304 per il montaggio a pavimento</li> <li>■ PUSH in alluminio pressofuso</li> </ul> <p><i>Pedestal mounted eyewash, with 2 opening controls (footboard/manual push), automatic flow reducer 12 l/min.</i></p> <ul style="list-style-type: none"> <li>■ eyewash bowl STAINLESS STEEL AISI 304</li> <li>■ support STAINLESS STEEL AISI 304 for floor mounting</li> <li>■ PUSH in die-cast aluminium</li> </ul>

# LAVAOCCHI A PARETE

WALL-MOUNTED EYEWASH



R290 11



R290 55

# LAVAOCCHI A PARETE CON DOCCETTA ESTRAIBILE

*WALL-MOUNTED EYEWASH  
WITH EXTRACTABLE SPRAY HEAD*



Vaschetta in abs con supporto  
in acciaio inox AISI 304

*Abs bowl and stainless steel  
AISI 304 support*

R290 16/3

# LAVAOCCHI A PARETE CON DOCCETTA ESTRAIBILE

*WALL-MOUNTED EYEWASH  
WITH EXTRACTABLE SPRAY HEAD*



Ottone fuso cromato  
apertura progressiva  
e dispositivo di erogazione continua

*Chromed fused brass progressive opening  
and continuous water supply device*

R290 57/2

# LAVAOCCHI A PARETE CON DOCGETTA ESTRAIBILE

*WALL-MOUNTED EYEWASH  
WITH EXTRACTABLE SPRAY HEAD*



Vaschetta e supporto  
in acciaio inox AISI 304  
*Stainless steel AISI 304  
bowl and support*

Flessibile in acciaio inox  
con attacco girevole  
*Stainless steel hose  
with swivel connection*

R290 57/3

**LAVAOCCHI A PARETE**  
**WALL MOUNTED EYEWASH**

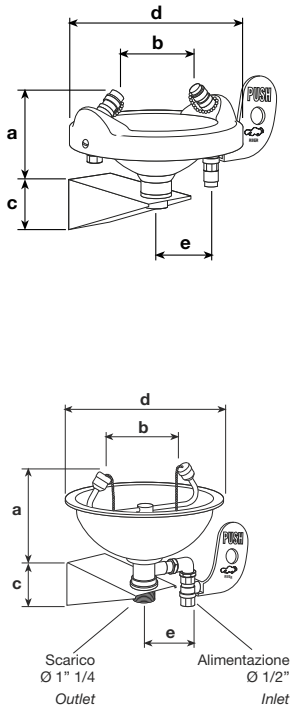

CODICE	mm a	mm b	mm c	mm d	mm e	NOTE
R290 11	185	180	100	300	130	Lavaocchi con supporto ACCIAIO INOX per il montaggio a parete, con riduttore automatico di portata - apertura a spinta - portata 12 litri/min. ■ vaschetta lavaocchi <b>ABS VERDE</b> ■ PUSH in alluminio pressofuso  <i>Wall mounted eyewash with STAINLESS STEEL support - automatic flow reducer - with push opening - flow rate 12 l/min.</i> ■ eyewash bowl <b>ABS GREEN</b> ■ PUSH in die-cast aluminium
R290 11/2	185	180	100	300	130	Lavaocchi come modello precedente - apertura a spinta ■ vaschetta lavaocchi <b>ABS GIALLO</b> ■ PUSH in alluminio pressofuso  <i>Eyewash as previous model - with push opening</i> ■ eyewash bowl <b>ABS YELLOW</b> ■ PUSH in die-cast aluminium
R290 55	230	175	100	300	100	Lavaocchi con supporto ACCIAIO INOX per il montaggio a parete con riduttore automatico di portata - apertura a spinta - portata 12 litri/min. ■ vaschetta lavaocchi <b>ACCIAIO INOX AISI 304</b> ■ PUSH in alluminio pressofuso  <i>Wall mounted eyewash with STAINLESS STEEL support - automatic flow reducer - with push opening - flow rate 12 l/min.</i> ■ eyewash bowl <b>STAINLESS STEEL AISI 304</b> ■ PUSH in die-cast aluminium



CODICE	mm a	mm b	mm c	NOTE
R290 11/3	350	165	250	Lavaocchi per il montaggio a parete Ø 1/2" - colore giallo senza vaschetta - apertura a spinta - doccia doppia - PUSH in alluminio pressofuso - portata 12 litri/min.  <i>Wall mounted eyewash Ø 1/2" - yellow colour - without bowl - with push opening - double spray head - PUSH in die-cast aluminium - flow rate 12 l/min.</i>

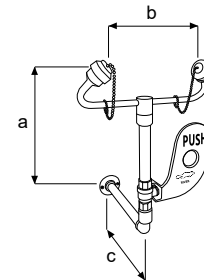

**LAVAOCCHI PARETE**  
**WALL MOUNTED EYEWASH**

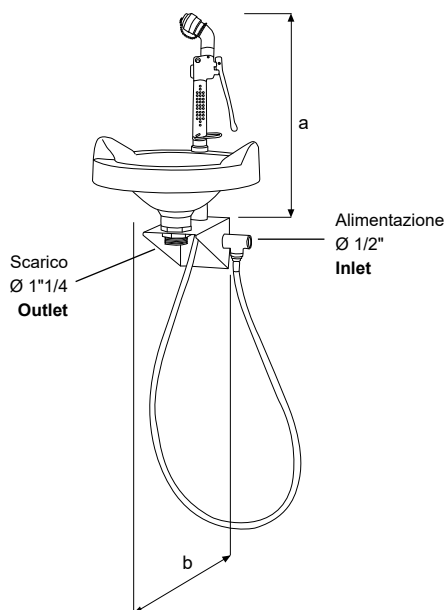

CODICE	mm a	mm b	NOTE
R290 16/3	380	425	<p>Lavaocchi con supporto ACCIAIO INOX per montaggio a parete - doccetta estraibile in ottone fuso cromato ad apertura rapida con dispositivo di erogazione continua - portata 12 litri/min. - flessibile inox mm.1500 con attacco girevole antiattorcigliamento</p> <p>■ vaschetta <b>ABS VERDE</b></p> <p>■ doccetta estraibile - curva 45° - impugnatura <b>VERDE</b> - R290 14/5</p> <p><i>Wall mounted eyewash with STAINLESS STEEL support - extractable chrome fused brass spray head at rapid opening with continuous water supply device - flow rate 12 l/min. - stainless steel hose mm.1500 with swivel connection anti-twisting</i></p> <p>■ bowl <b>ABS GREEN</b></p> <p>■ extractable spray head, 45° curved, handle <b>GREEN</b>, R290 14/5</p>
R290 16/4	400	425	<p><b>Come articolo precedente:</b></p> <p>■ vaschetta <b>ABS VERDE</b></p> <p>■ doccetta estraibile - doppia - impugnatura <b>VERDE</b> - R290 13/7 - portata 12 l/min.</p> <p><i>As previous model:</i></p> <p>■ bowl <b>ABS GREEN</b></p> <p>■ extractable spray head, double, handle <b>GREEN</b>, R290 13/7, flow rate 12 l/min.</p>

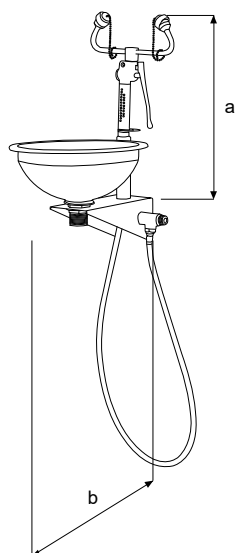

R290 57/2	380	425	<p>Lavaocchi come modello precedente:</p> <p>■ vaschetta <b>ACCIAIO INOX AISI 304</b></p> <p>■ doccetta estraibile - curva 45° - impugnatura <b>GIALLA</b> - R290 14/6 - portata 12 l/min.</p> <p><i>Eyewash as previous model:</i></p> <p>■ bowl <b>STAINLESS STEEL AISI 304</b></p> <p>■ extractable spray head, 45° curved, handle <b>YELLOW</b>, R290 14/6, flow rate 12 l/min.</p>
R290 57/3	400	425	<p><b>Come articolo precedente:</b></p> <p>■ vaschetta <b>ACCIAIO INOX AISI 304</b></p> <p>■ doccetta estraibile - doppia - impugnatura <b>GIALLA</b> - R290 13/2 - portata 12 l/min.</p> <p><i>As previous model:</i></p> <p>■ bowl <b>STAINLESS STEEL AISI 304</b></p> <p>■ extractable spray head, double, handle <b>YELLOW</b>, R290 13/2, flow rate 12 l/min.</p>



# LAVAOCCHI PER IL MONTAGGIO SUL BANCO DI LAVORO

## DECK MOUNTED EYEWASH

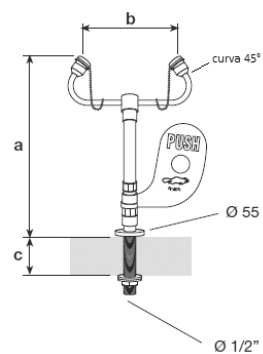
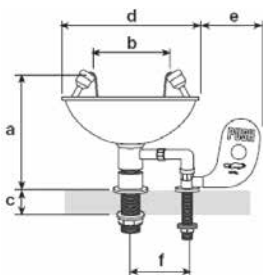
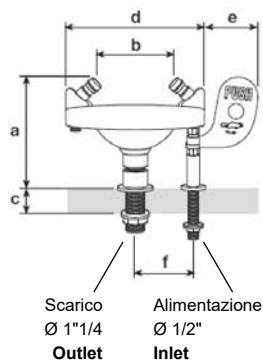

CODICE	mm a	mm b	mm c	mm d	mm e	mm f	NOTE
R290 18	243	180	max 100	300	125	130	Lavaocchi per il montaggio sul banco di lavoro - apertura a spinta - portata 12 litri/min. - PUSH in alluminio pressofuso ■ vaschetta lavaocchi ABS VERDE  <i>Deck mounted eyewash - with push opening - flow rate 12 l/min. - PUSH in die-cast aluminium ■ eyewash bowl ABS GREEN</i>
R290 18/2	243	180	max 100	300	125	130	Lavaocchi per il montaggio sul banco di lavoro - apertura a spinta - portata 12 litri/min. - PUSH in alluminio pressofuso ■ vaschetta lavaocchi ABS GIALLO  <i>Deck mounted eyewash - with push opening - flow rate 12 l/min. - PUSH in die-cast aluminium ■ eyewash bowl ABS YELLOW</i>
R290 56	300	175	max 100	300	100	100	Lavaocchi per il montaggio fisso sul banco di lavoro - apertura a spinta - portata 12 litri/min. - PUSH in alluminio pressofuso ■ vaschetta lavaocchi ACCIAIO INOX AISI 304  <i>Fixed deck mounted eyewash - with push opening - flow rate 12 l/min. - PUSH in die-cast aluminium ■ eyewash bowl STAINLESS STEEL AISI 304</i>

R290 17	340	175	max 100				Doccetta lavaocchi doppia in ottone fuso cromato senza vaschetta - montaggio fisso su banco di lavoro - aperture a spinta - portata 15 litri/min. - PUSH in alluminio pressofuso - foratura mm.24 ■ colore GIALLO  <i>Double eyewash spray heads in chrome fused brass without bowl - fixed mounted on work bench - with push opening - flow rate 15 l/min. - PUSH in die-cast aluminium - hole mm. 24 ■ colour YELLOW</i>
---------	-----	-----	---------	--	--	--	---

**LAVAOCCHI PER LAVELLO**  
EYEWASH FOR SINK

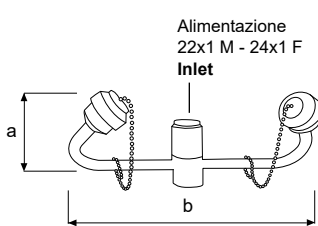

CODICE	mm a	mm b	NOTE
R290 18/5	70	240	<p>Il lavaocchi può essere facilmente montato su tutte le bocche di erogazione con filettatura 22x1 M e 24x1 F (adattatore in dotazione). Può essere utilizzato anche come normale bocca di erogazione. Bilanciatore di portata per una erogazione costante</p> <p><i>The eyewash can be easily mounted on all the spouts with thread 22x1 M and 24x1 F (adapter supplied). It can also be used as a normal spout. Flow balancer for a constant water supply</i></p> 

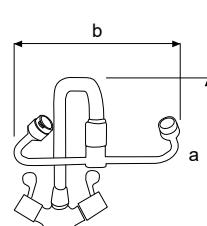

CODICE	mm a	mm b	NOTE
R290 18/8	290	240	<p>Lavaocchi come articolo precedente completo di rubinetto monoforo con cartuccia in ceramica - maniglia in ottone lucidato e cromato con apertura facilitata. La bocca di erogazione orientabile permette anche un normale utilizzo del rubinetto.</p> <p><i>Eyewash as a previous model complete with single-hole tap with ceramic cartridge - polished and chromed brass handle with easy opening. The adjustable spout allows also a normal use of the tap.</i></p> 

ANTIGELO  
ANTICALORE  
*ANTIFREEZE  
ANTI HEAT*

LAVAOCCHI  
A PAVIMENTO  
*FLOOR-MOUNTED EYEWA-  
SH*

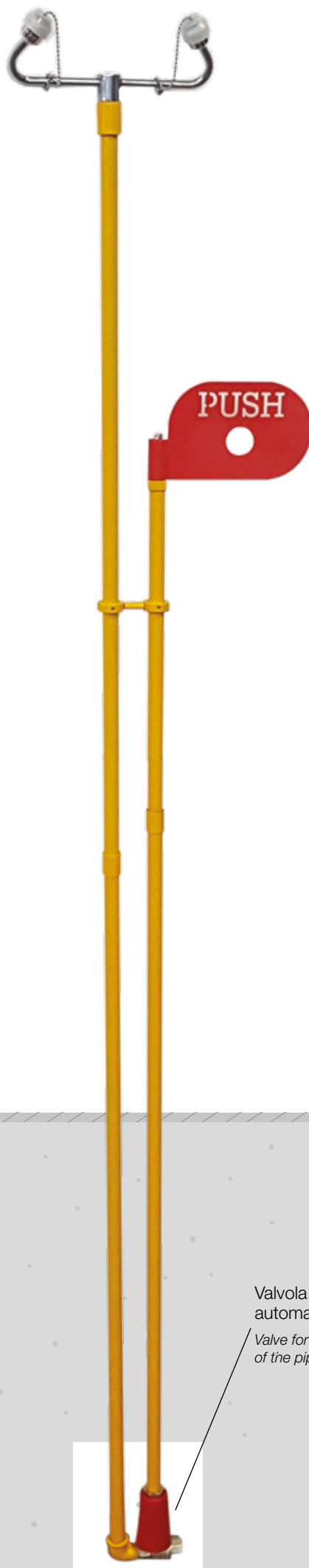

Installazione a una profondità  
di 1 metro dal suolo

*For installation at a depth  
of 1 meter from the ground*

Valvola per lo svuotamento  
automatico dei tubi

*Valve for automatic emptying  
of the pipes*

R290, 15/5X

# ANTIGELO ANTICALORE

*ANTIFREEZE  
ANTI HEAT*



Valvola per lo svuotamento  
automatico dei tubi  
*Valve for automatic emptying  
of the pipes*

# LAVAOCCHI CON ALIMENTAZIONE DIETRO PARETE

*EYEWASH WITH FEEDING BEHIND  
WALL*

**LAVAOCCHI D'EMERGENZA ANTIGELO-ANTICALORE**  
**EMERGENCY EYEWASH ANTIFREEZE - ANTI HEAT**

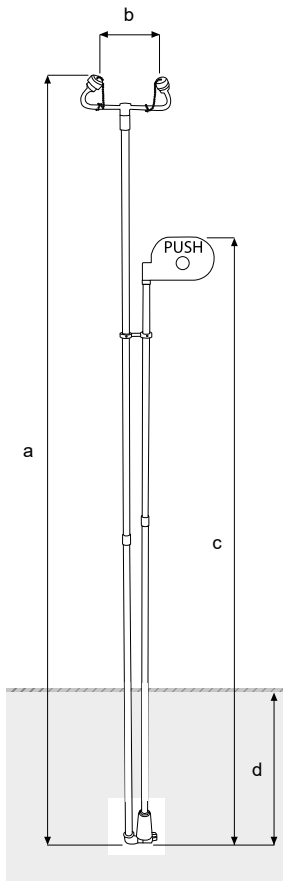

CODICE	mm a	mm b	mm c	mm d	mm e	NOTE
R290 15/5X	2050	175	1910	1000		<p><b>antigelo - anticalore</b>                      Lavaocchi d'emergenza a <b>pavimento</b> con apertura manuale colore giallo. <b>Per l'alimentazione è necessario prevedere per il drenaggio un pozzetto con il fondo in ghiaia ad una profondità di circa 1 metro dal suolo.</b> Una speciale valvola Ø ½" permette alle tubazioni di vuotarsi completamente dopo l'utilizzo per evitare la formazione di ghiaccio o il surriscaldamento dell'acqua contenuta nei tubi.</p> <p><i>antifreeze - anti heat</i>                      Floor mounted emergency eyewash with manual opening - yellow colour. For feeding it is necessary to provide for drainage a little well with a gravel bottom at a depth of about 1 meter from the ground. A special Ø ½" valve allows the pipes to drain completely after use to avoid ice formation or overheating of the water contained in the pipes.</p>

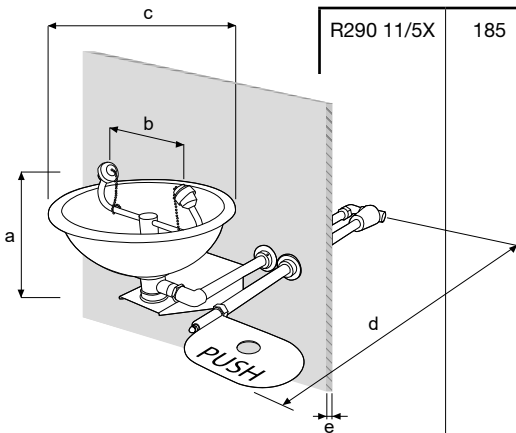

R290 11/5X	185	180	300	750	max 300	<p><b>antigelo - anticalore</b>                      Lavaocchi d'emergenza a <b>parete</b> con vaschetta ABS colore giallo con apertura manuale - una speciale valvola Ø ½" permette alle tubazioni di vuotarsi completamente dopo l'utilizzo per evitare la formazione di ghiaccio o il surriscaldamento dell'acqua contenuta nei tubi.</p> <p>■ <b>vaschetta lavaocchi ABS GIALLO</b></p> <p><i>antifreeze - anti heat</i>                      Wall mounted emergency eyewash with yellow ABS bowl with manual opening - special Ø ½" valve allows the pipes to drain completely after use to avoid ice formation or overheating of the water contained in the pipes.</p> <p>■ <b>eyewash bowl ABS YELLOW</b></p>
R290 55/5X	230	175	300	750	max 300	<p><b>antigelo - anticalore</b>                      Lavaocchi d'emergenza a <b>parete</b> di colore giallo - caratteristiche come articolo precedente</p> <p>■ <b>vaschetta lavaocchi ACCIAIO INOX AISI 304</b></p> <p><i>antifreeze - anti heat</i>                      Wall mounted emergency eyewash - yellow colour - as previous model</p> <p>■ <b>eyewash bowl STAINLESS STEEL AISI 304</b></p>



dal 1980

MADE IN ITALY

# DISPOSITIVO AUTOMATICO ANTIGELO ANTICALORE

*AUTOMATIC DEVICE  
ANTI-FREEZE ANTI-HEAT*

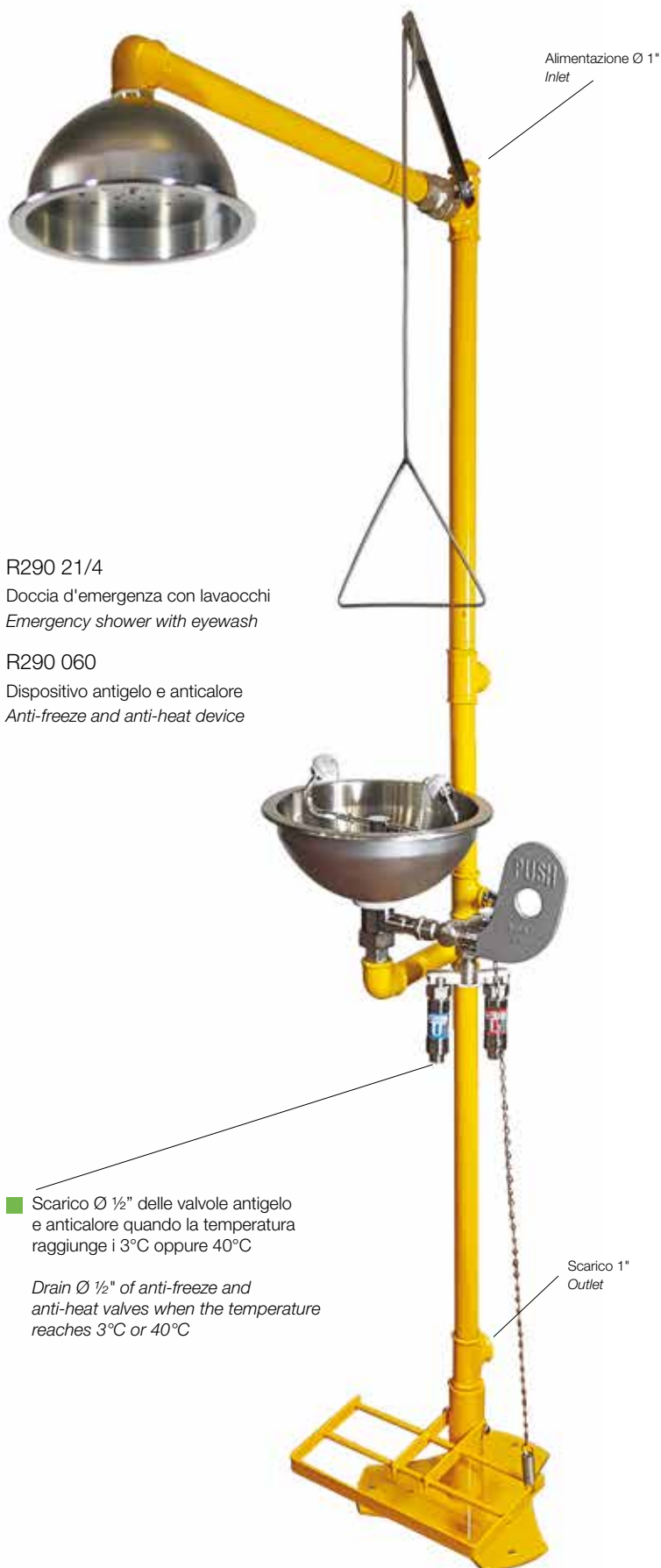

R290 54/2  
Lavacchi a pavimento  
*Floor-mounted eyewash*

R290 060  
Dispositivo antigelo e anticalore  
*Anti-freeze and anti-heat device*

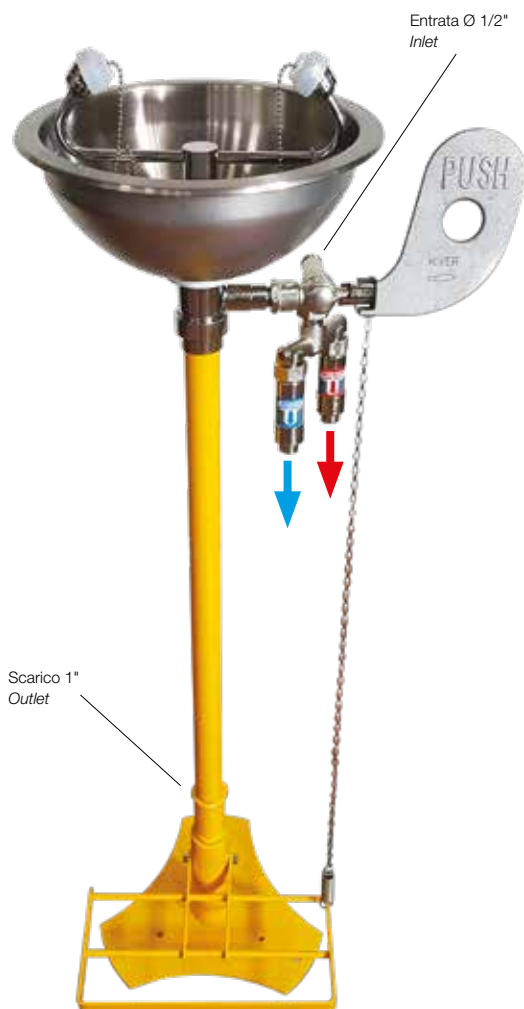

# DISPOSITIVO AUTOMATICO ANTIGELO ANTICALORE

*AUTOMATIC DEVICE  
ANTI-FREEZE ANTI-HEAT*



R 290 55

Lavaocchi a parete  
*Wall mounted eyewash*

R 290 060

Dispositivo antigelo anticalore  
*Anti-freeze anti-heat device*



R 290 53/4

Doccia d'emergenza  
*Emergency shower*

R 290 061

Dispositivo antigelo anticalore  
*Anti-freeze anti-heat device*

Alimentazione 1"  
*Inlet*

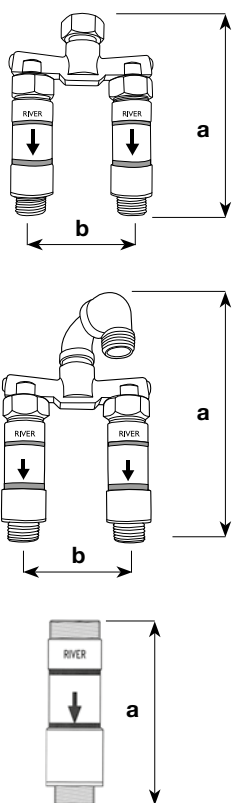

CODICE	mm a	mm b	NOTE
R290 060	145	75	Collettore in ottone nichelato Ø ¾" per il montaggio sulle colonne doccia CON lavaocchi inox completo di valvola antigelo e la valvola anticalore <i>Collector in nickered brass Ø ¾" for mounting on shower columns WITH stainless steel eyewash complete with anti-freeze and anti-heat valve</i>
R290 061	168	75	Collettore in ottone nichelato per il montaggio sulle colonne doccia SENZA lavaocchi predisposto per la valvola antigelo e la valvola anticalore <i>Collector in nickered brass for mounting on shower columns WITHOUT eyewash set for the anti-freeze and anti-heat valve</i>
R290 065	97		Valvola termostatica antigelo Ø ¾" - alla temperatura di circa 3°C la valvola si apre e fa scorrere l'acqua - si richiude automaticamente <i>Anti-freeze thermostatic valve Ø ¾" - at a temperature of about 3°C the valve opens and make run the water - it closes automatically</i>
R290 066	97		Valvola termostatica anticalore Ø ¾" - alla temperatura di circa 40°C la valvola si apre e non permette così accumulo di acqua calda - si richiude automaticamente <i>Anti-heat thermostatic valve Ø ¾" - at a temperature of about 40°C the valve opens and does not allow hot water to accumulate - it closes automatically</i>





DOCCHETTE ESTRAIBILI  
CON APERTURA  
RAPIDA PER MONTAGGIO  
SUL BANCO DI LAVORO  
*EXTRACTABLE SPRAY HEADS,  
WITH RAPID OPENING  
FOR MOUNTING ON WORKBENCH*

**DOCCHETTE LAVAOCCHI / LAVAVISO ESTRAIBILI**  
**EXTRACTABLE EYE/FACE WASH SPRAY HEAD**

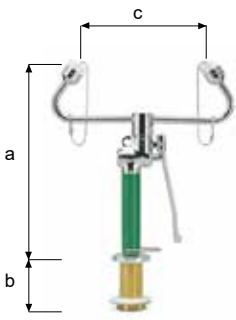



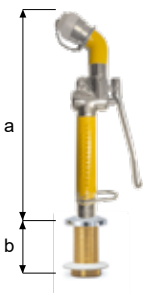
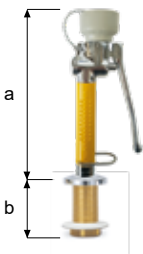
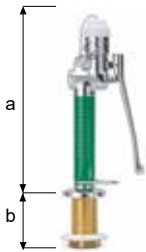

Supporto filettato  
con dado di fissaggio  
*Threaded support  
with fixing nut*



CODICE	mm a	mm b	mm c	NOTE
R290 15	275	max 50	165	Doccetta lavaocchi doppia <b>estraibile</b> in ottone fuso cromato <b>per il montaggio sul banco di lavoro</b> completa di flessibile inox mm.1500 con attacco antiattorcigliamento - apertura rapida - portata a 3 bar 12 litri/min. - alimentazione Ø ½" - foratura mm. 34 ■ impugnatura VERDE  <i>Extractable deck mounted double eyewash spray heads in chrome fused brass - stainless steel hose mm.1500 with swivel connection anti-twisting - at rapid opening - flow rate at 3 bar 12 l/min.- inlet Ø ½" - hole mm. 34</i> ■ handle GREEN
R290 15/2	275	max 50	165	Doccetta lavaocchi come mod. precedente ■ impugnatura GIALLA  <i>Spray heads eyewash as previous model</i> ■ handle YELLOW
R290 16	215	max 50		Doccetta lavaocchi diritta <b>estraibile per il montaggio sul banco di lavoro</b> - portata 12 litri/min. - come art. precedente ■ impugnatura VERDE  <i>Extractable deck mounted straight eyewash spray head - flow rate 12 l/min.- as previous model</i> ■ handle GREEN
R290 16/2	215	max 50		Doccetta lavaocchi estraibile come mod. precedente ■ impugnatura GIALLA  <i>Extractable eyewash spray head as previous model</i> ■ handle YELLOW
R290 16/5	215	max 50		Doccetta lavaocchi/lavaviso diritta <b>estraibile</b> in ottone fuso cromato <b>per il montaggio sul banco di lavoro</b> completa di flessibile inox mm.1500 con attacco antiattorcigliamento - apertura rapida - portata a 3 bar 16 litri/min. - alimentazione Ø ½" - foratura mm. 34 ■ impugnatura VERDE, testa doccia grigio  <i>Extractable deck mounted straight eye/face wash spray head in chrome fused brass - stainless steel hose mm.1500 with swivel connection anti-twisting - at rapid opening - flow rate at 3 bar 16 l/min.- inlet Ø ½" - hole mm. 34</i> ■ handle GREEN, shower head grey
R290 16/6	215	max 50		Doccetta lavaocchi/lavaviso estraibile come mod. precedente ■ impugnatura GIALLA  <i>Extractable eye/face wash spray head as previous model</i> ■ handle YELLOW
R290 19	260	max 50		Doccetta lavaocchi curva 45° <b>estraibile per il montaggio su banco di lavoro</b> completa di flessibile inox mm.1500 - portata 12 litri/min. come mod. precedente ■ impugnatura VERDE  <i>Extractable deck mounted eyewash spray head - 45° curved - stainless steel hose mm.1500 - flow rate 12 l/min. - as previous model</i> ■ handle GREEN
R290 19/2	260	max 50		Doccetta lavaocchi curva 45° - estraibile come mod. precedente ■ impugnatura GIALLA  <i>Extractable eyewash spray head eyewash - 45° curved - as previous model</i> ■ handle YELLOW

**PEZZI STACCATI**  
**SEPARATE PARTS**

	CODICE	Ø	mm a	mm b	NOTE
	R290 14/3	1/2"	215		Solo doccetta lavaocchi /lavaviso in ottone fuso cromato - apertura rapida con dispositivo di erogazione continua - portata a 3 bar 16 litri/min. ■ impugnatura VERDE, testa doccia grigio  <i>Only eye/face wash spray head in chromed fused brass - rapid opening with continuous water device - flow rate at 3 bar 16 l/min</i> ■ handle GREEN, shower head grey
	R290 14/4	1/2"	215		Come mod. precedente ■ impugnatura GIALLA, testa doccia grigio  <i>As previous model</i> ■ handle YELLOW, shower head grey
	R290 14/7	1/2"	215		Solo doccetta lavaocchi in ottone fuso cromato - apertura rapida con dispositivo di erogazione continua - portata a 3 bar 12 litri/min. ■ impugnatura VERDE  <i>Only eyewash spray head in chromed fused brass - rapid opening with continuous water device - flow rate at 3 bar 12 l/min</i> ■ handle GREEN
	R290 14/2	1/2"	215		Come mod. precedente ■ impugnatura GIALLA  <i>Only eye/face wash spray head as previous model</i> ■ handle YELLOW
	R290 14/5	1/2"	260		Solo doccetta lavaocchi come mod. precedente ■ impugnatura VERDE, curva 45°  <i>Only eyewash spray head as previous model</i> ■ handle GREEN, 45° curved
	R290 14/6	1/2"	260		Come mod. precedente ■ impugnatura GIALLA, curva 45°  <i>Only eye/face wash spray head as previous model</i> ■ handle YELLOW, 45° curved
	R290 13/7	1/2"	275	165	Solo doccetta lavaocchi doppia in ottone fuso cromato - apertura rapida con dispositivo di erogazione continua - portata a 3 bar 12 litri/min. ■ impugnatura VERDE  <i>Only double eyewash spray heads - chromed fused brass - rapid opening with continuous water device - flow rate at 3 bar 12 l/min</i> ■ handle GREEN
	R290 13/2	1/2"	275	165	Come mod. precedente ■ impugnatura GIALLA  <i>As previous model</i> ■ handle YELLOW
	800/2015	1/2"			Flessibile in acciaio inox rivestito colore grigio mm. 1500 Ø 1/2" con attacco antiattorcigliamento per art. R290 21/14  <i>Stainless steel coated hose - gray colour - mm. 1500 Ø 1/2" with anti-twisting connection - for art. R290 21/14</i>
	800/2016	1/2"			<b>Flessibile in acciaio inox mm. 1500 Ø 1/2" - 15x1 M con attacco antiattorcigliamento per tutte le doccette lavaocchi estraibili</b>  <i>stainless steel hose mm. 1500 Ø 1/2" - 15x1 M with anti-twisting connection - for all extractable eyewash spray head</i>

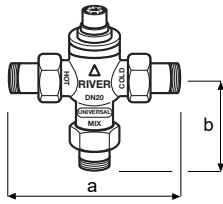
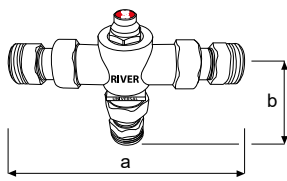

CODICE	Ø	mm a	mm b	NOTE
R290DN15/10	1/2"	120	69	<p>Speciale miscelatore termostatico per lavacocchi/lavaviso prearato a 35°C completo di valvole di non ritorno e codoli - portata a 2 bar l/min. 40 - regolazione da 20 a 35°C - dispositivo antiscottatura se manca l'alimentazione fredda chiude l'erogazione - se manca la calda l'erogazione è di l/min. 25</p> <p><i>Special thermostatic mixer for eye/face wash pre-calibrated at 35°C complete with non-return valves and tangs - flow rate at 2 bar l/min. 40 - adjustment from 20 to 35°C - anti-scalding device if the cold supply is missing closes the water supply - if the hot is missing the water supply is l/min. 25</i></p> 
R290DN25/11	1"	189	89	<p>Speciale miscelatore termostatico per docce d'emergenza prearato a 35°C completo di valvola di non ritorno e codoli - portata a 2 bar l/min. 105 - regolazione da 20 a 35°C - dispositivo antiscottatura se manca l'alimentazione fredda chiude l'erogazione - se manca la calda l'erogazione è di l/min. 75</p> <p><i>Special thermostatic mixer for emergency showers pre-calibrated at 35°C complete with non-return valve and tangs - flow rate at 2 bar l/min. 105 - adjustment from 20 to 35°C - anti-scalding device if the cold supply is missing closes the water supply - if the hot is missing the water supply is l/min. 75</i></p> 



SICUREZZA SUL LAVORO - SAFETY AT WORK



dal 1980  
MADE IN ITALY

I dispositivi saranno installati in fabbrica sugli apparecchi di emergenza indicati dal cliente  
 The devices will be installed at the factory on emergency devices indicated by the customer



CODICE	NOTE	
RE 101 290	<p><b>SISTEMA DI ALLARME PER DOCCE</b>                      Scatola di derivazione <b>con lampeggiante</b> da installare sulla doccia di emergenza con segnale di allarme luminoso/acustico che si attiva azionando la leva di apertura - grado di protezione IP 54 - <b>per impianti in zone di lavoro coperte</b> - il dispositivo deve essere alimentato 12V DC (alimentatore non compreso) - in dotazione supporto di montaggio in acciaio inox</p> <p><i>ALARM SYSTEM FOR SHOWERS</i>                      Junction box with flashing light to be installed on the emergency shower with luminous/acoustic alarm signal which is activated by actuating the opening lever - degree of protection IP 54 - for plants in covered working areas - the device must be powered 12V DC (power supply not included) - supplied with mounting bracket in stainless steel</p>	
RE 102 290	<p><b>SISTEMA DI ALLARME PER DOCCE</b>                      Scatola di derivazione <b>con lampeggiante</b> da installare sulla doccia di emergenza con segnale di allarme luminoso/acustico (100dB) che si attiva azionando la leva di apertura - grado di protezione IP 65 - <b>può essere utilizzato anche in impianti all'esterno</b> - il dispositivo deve essere alimentato 9V DC (alimentatore non compreso) - in dotazione supporto di montaggio in acciaio inox</p> <p><i>ALARM SYSTEM FOR SHOWERS</i>                      Junction box with flashing light to be installed on the emergency shower with luminous/acoustic (100 dB) alarm signal which is activated by actuating the opening lever - degree of protection IP 65 - it can be used in outdoor installations - the device must be powered by 9V DC (power supply not included) - supplied with mounting bracket in stainless steel</p>	
RE 103 290	<p><b>SISTEMA AUTONOMO DI ALLARME PER DOCCE E LAVAOCCHI</b>  <input type="checkbox"/> <b>trasmettitore speciale da installare senza impianto elettrico</b> sulla doccia e sul lavaocchi di emergenza completo di batteria (durata circa 5 anni) - grado di protezione IP 65 - <b>può essere utilizzato anche in impianti all'esterno</b> - in dotazione supporto di montaggio in acciaio inox</p> <p><input type="checkbox"/> <b>ricevitore</b> di allarme wireless luminoso/acustico (85dB) compreso di alimentatore 230V-12V - può essere installato fino ad una distanza massima di circa 100 metri in area libera dal trasmettitore, ampliabile con il ripetitore di segnale cod. RE 113 290 - installazione in zone di lavoro coperte - IP40</p> <p><i>AUTONOMOUS ALARM SYSTEM FOR SHOWERS AND EYEWASH</i>  <input type="checkbox"/> <i>special transmitter to be installed without electrical installation on the shower and on the emergency eyewash complete with battery (battery life about 5 years) - degree of protection IP 65 - can be used in outdoor installations - supplied with mounting bracket in stainless steel</i>  <input type="checkbox"/> <i>luminous/acoustic (85dB) wireless alarm receiver with 230V-12V power supply - it can be installed up to a maximum distance of about 100 meters in a free area from the transmitter, expandable with the signal repeater cod. RE 113 290 - installation in covered work areas - IP40</i></p>	
RE 111 290	<p>Solo ricevitore di allarme wireless luminoso/acustico completo di alimentatore 230V-12V da installare ad una distanza massima di circa 100 metri in area libera dal trasmettitore - installazione in zone di lavoro coperte - IP40                      104X86X38 mm</p> <p><i>Only luminous/acoustic wireless alarm receiver with 230V-12V power supply to be fixed at a maximum distance of about 100 meters in a free area from the transmitter - installation in covered work areas - IP40</i></p>	
RE 112 290	<p>Speciale ricevitore di allarme <b>portatile</b> da tasca/cintura con display LCD con funzione suoneria e vibrazione - ricaricabile                      76x53x18 mm</p> <p><i>Special portable pocket / belt alarm receiver with LCD display with ringtone and vibration function - rechargeable</i></p>	
RE 113 290	<p>Ripetitore di segnale                      95x82x24 mm</p> <p><i>Signal repeater</i></p>	



CODICE	mm a	mm b	NOTE
R290 30	250	310	<b>Segnale di soccorso in alluminio - spessore 0,5 mm. - docce di emergenza per la decontaminazione rif. UNI7546/3 - colore di fondo verde con segno grafico bianco mm.250x310</b>  <i>Safety sign in aluminum - thickness 0,5 mm. - emergency showers for the decontamination ref. UNI7546 / 3 - green background color with white graphic sign mm.250x310</i>
R290 31	250	310	<b>Segnale di soccorso in alluminio - spessore 0,5 mm. -lavoocchi/lavaviso rif. UNI7546/4 - colore di fondo verde con segno grafico bianco mm.250x310</b>  <i>Safety sign in aluminum - thickness 0,5 mm. - eye/face wash ref. UNI7546/4 - green background color with white graphic sign mm.250x310</i>

R290 30/2	210	210	<b>Segnale di soccorso in polipropilene - spessore 1 mm. - immagine su 2 lati - stessi colori mod. precedente</b>  <i>Safety sign in polypropylene - thickness 1 mm. - image on 2 sides - same colours as previous model</i>
R290 31/2	210	210	<b>Segnale di soccorso in polipropilene - spessore 1 mm. - immagine su 2 lati - stessi colori mod. precedente</b>  <i>Safety sign in polypropylene - thickness 1 mm. - image on 2 sides - same colours as previous model</i>
R290 31/4	210	410	<b>Segnale di soccorso doppio in polipropilene - spessore 1 mm. - immagine su 2 lati - doccia d'emergenza e lavaocchi/lavaviso - colore disegno verde con segno grafico bianco</b>  <i>Double safety sign in polypropylene - thickness 1mm.- image on 2 sides - emergency shower and eye/face wash - colour drawing green with white graphic sign</i>