

MINIECO SOLAR

Valvola deviatrice termostatica

Diverter thermostatic valve

- Devia automaticamente l'acqua calda proveniente dal pannello alla caldaia solo quando è necessario integrarne la temperatura.

Diver automatically the hot water coming from the panel to the boiler only when it is necessary integrate the temperature.

- Portata a 3 bar 45 litri/minuto.

Flow rate 3 bar 45 l/min.



R 00401

- Temperatura massima di entrata acqua calda 110°C e taratura fissa di uscita.

Maximum temperature hot water inlet 110°C and fix calibration outlet.

- Elemento termostatico anticalcare con risposta ultra rapida.

ANTI-scale thermostatic unit with high-speed response.

- Pannello solare a circolazione naturale.

Solar panel with natural circulation.

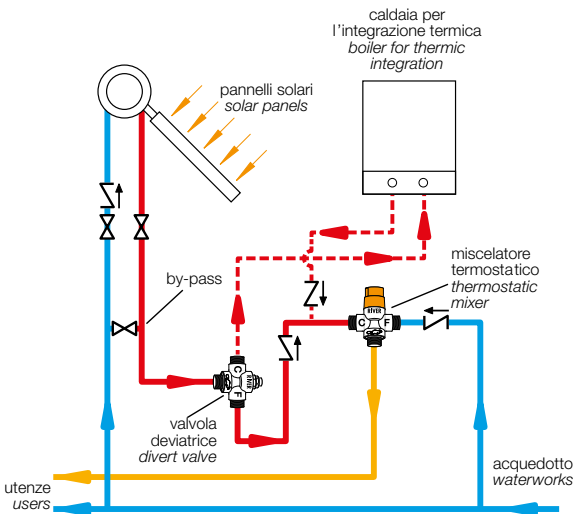

- Pannello solare a circolazione forzata.

Solar panel with forced circulation.

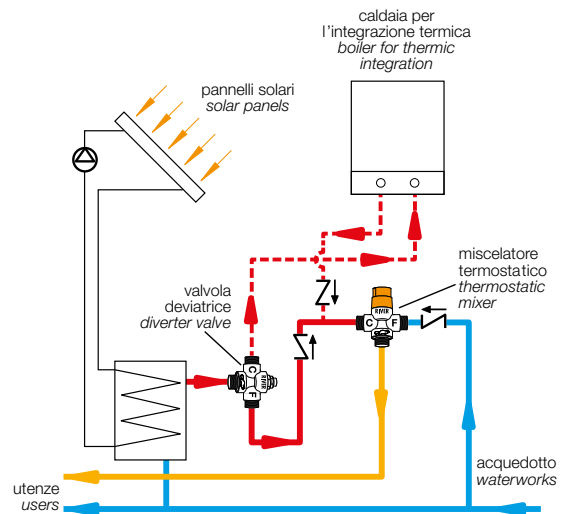

	Valvola di non ritorno <i>Non-return valve</i>
	Pompa di circolazione <i>Circulation pump</i>
	Saracinesca <i>Gate valve</i>

MINIECO

VALVOLA DEVIATRICE TERMOSTATICA
DIVERTER THERMOSTATIC VALVE

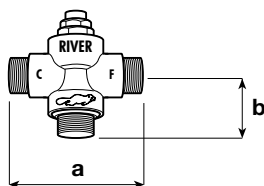

CODICE	Ø	mm a	mm b	NOTE
R 00400	3/4"	90	44	Valvola deviatrice termostatica a 3 vie con taratura fissa 40°C – senza valvole di non ritorno <i>Diverter thermostatic valve 3 way with fix calibration 40°C – without non return valves</i>
R 00401	3/4"	90	44	Idem 45°C <i>Ditto 45°C</i>
R 00402	3/4"	90	44	Idem 50°C <i>Ditto 50°C</i>

- Su richiesta taratura con temperatura diversa

On request calibration with different temperature

MINIECO SOLAR

Kit termostatico premontato per il collegamento facilitato dal pannello solare alla caldaia di integrazione

Pre-assembled thermostatic kit for facilitate connection from the solar panel to the boiler for thermic integration

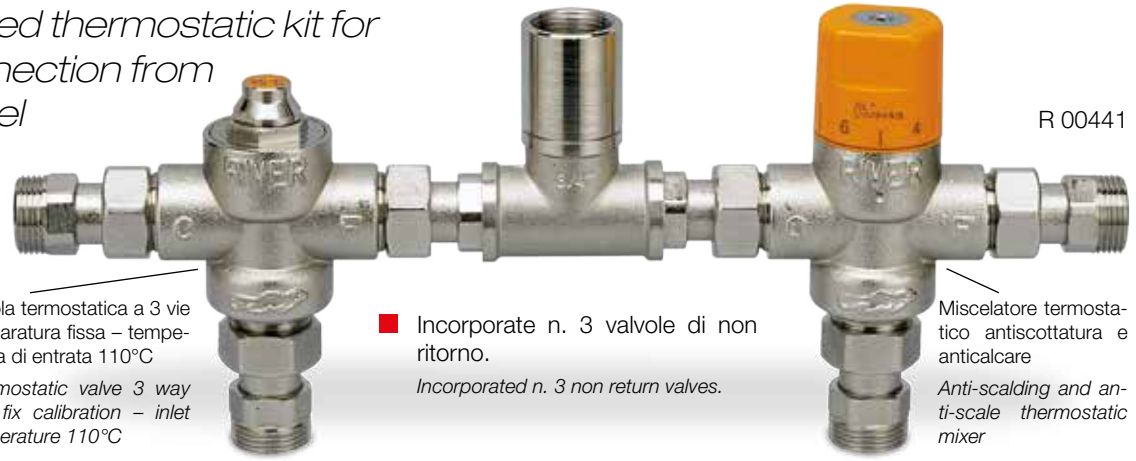

R 00441

Valvola termostatica a 3 vie con taratura fissa - temperatura di entrata 110°C
 Thermostatic valve 3 way with fix calibration - inlet temperature 110°C

■ Incorporate n. 3 valvole di non ritorno.
 Incorporated n. 3 non return valves.

Miscelatore termostatico antiscottatura e anticalcare
 Anti-scalding and anti-scale thermostatic mixer

■ Pannello solare a circolazione naturale.
 Solar panel with natural circulation.

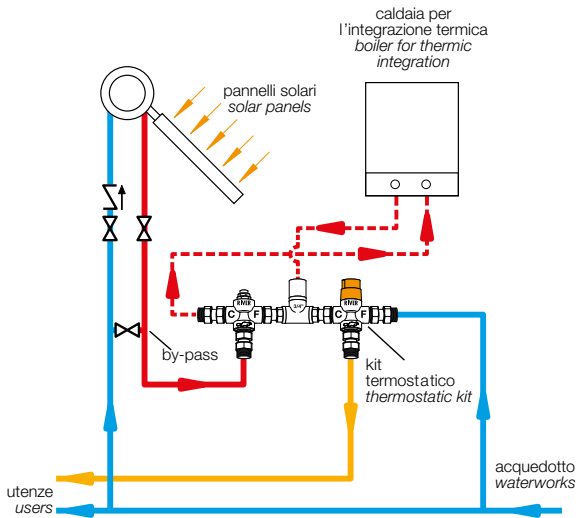

■ Pannello solare a circolazione forzata.
 Solar panel with forced circulation.

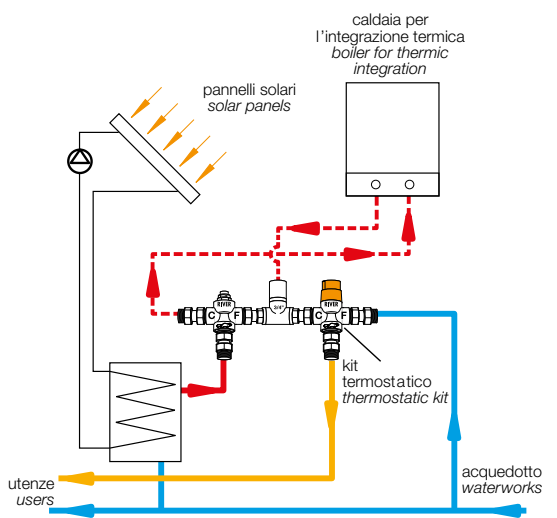

Valvola di non ritorno
 Non-return valve
 Pompa di circolazione
 Circulation pump
 Saracinesca
 Gate valve

MINIECO KIT TERMOSTATICO CON VALVOLA DEVIATRICE E MISCELATORE
THERMOSTATIC KIT WITH DIVERTER VALVE AND MIXER

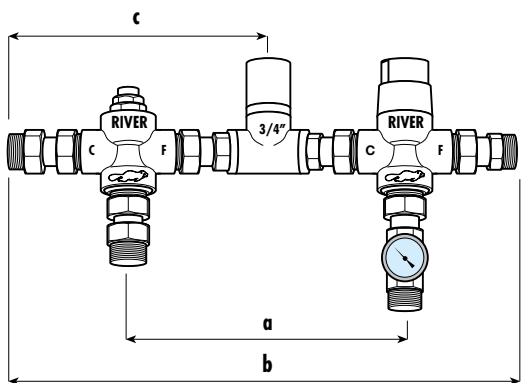
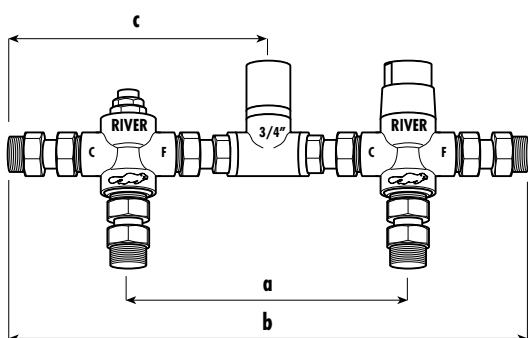

CODICE	Ø	mm a	mm b	mm c	NOTE
R 00440	3/4"	198	360	180	Kit di collegamento completo di miscelatore termostatico antiscottatura con temperatura di entrata acqua calda 110°C - valvola deviatrice termostatica con taratura fissa 40°C - 3 valvole di non ritorno per alta temperatura, filtri inox e codoli Complete connection kit of anti-scalding thermostatic mixer with hot water inlet 110°C - diverter thermostatic valve with fix calibration 40°C - non return valves, stainless steel filters and tangs
R 00441	3/4"	198	360	180	Idem 45°C Ditto 45°C
R 00442	3/4"	198	360	180	Idem 50°C Ditto 50°C
R 00445	3/4"	198	360	180	Kit di collegamento come modello precedente completo di termometro ad immersione Kit complete with immersion thermometer
R 00446	3/4"	198	360	180	Idem 45°C Ditto 45°C
R 00447	3/4"	198	360	180	Idem 50°C Ditto 50°C

VALVOLE DEVIATRICI TERMOSTATICHE PRETARATE E REGOLABILI Ø 3/4"-1"

THERMOSTATIC DIVERTER VALVE PRESET AND ADJUSTABLE Ø 3/4"-1"

Deviano automaticamente l'acqua calda da una via ad un'altra quando la temperatura dell'acqua è diversa dalla temperatura di taratura indicata sulla valvola.

Negli impianti con pannelli solari deviano, se necessario, l'acqua calda proveniente dal pannello solare alla caldaia di integrazione.

Automatically diverts the hot water from one circuit into another when the temperature of the water is different from the calibration temperature indicated on the valve.

In the plants with solar panels if necessary, diverts the hot water coming from the solar panel to the boiler for thermic integration.

- Possibilità di modificare facilmente la temperatura di taratura.

Possibility of modify easily the calibration temperature.

- Temperatura massima acqua calda 110°C.

Maximum temperature hot water 110°C.



litri/minuto Ø 3/4"
flow rate

R 00481

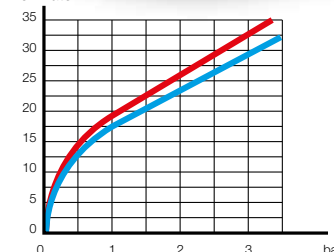

litri/minuto Ø 1"
flow rate

R 00485

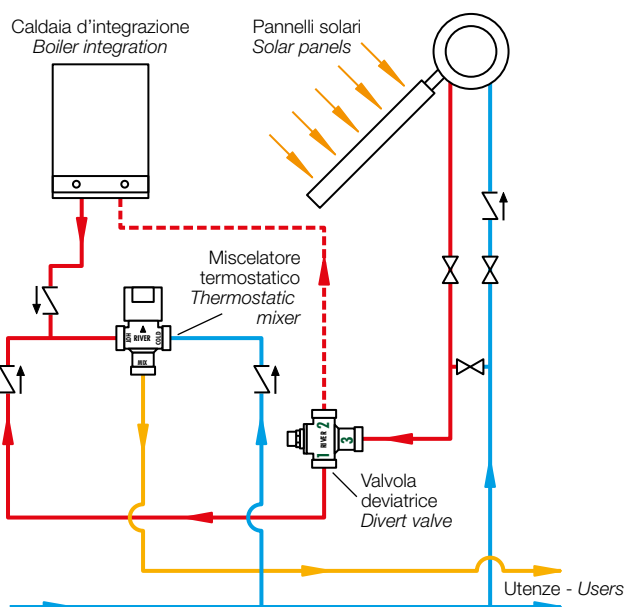
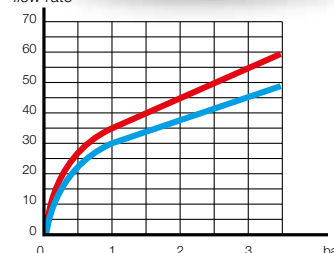

↗ Valvola di non ritorno
Non-return valve

⊗ Saracinesca
Gate valve

VALVOLE DEVIATRICI TERMOSTATICHE PRETARATE E REGOLABILI THERMOSTATIC DIVERTER AND ADJUSTABLE VALVES

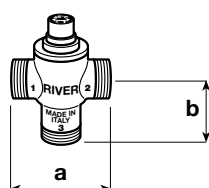

CODICE	Ø	mm a	mm b	NOTE
R 00480	3/4"	63	42	Valvola deviatrice termostatica a 3 vie, pretarata in fabbrica a 40°C con possibilità di modificare la temperatura di taratura - senza valvole di non ritorno <i>Thermostatic diverter valve 3-way, factory preset to 40°C with possibility of adjustment the calibration temperature - without non return valves</i>
R 00481	3/4"	63	42	Idem 45°C Ditto 45°C
R 00484	1"	75	44	Idem 40°C Ditto 40°C
R 00485	1"	75	44	Idem 45°C Ditto 45°C

- Su richiesta taratura con temperatura diversa.

On request calibration with different temperature.

UNIVERSAL Ø 3/4" - 1"

Kit termostatico per il collegamento del pannello solare alla caldaia di integrazione

Thermostatic kit for the connection of the solar panel to the integration boiler

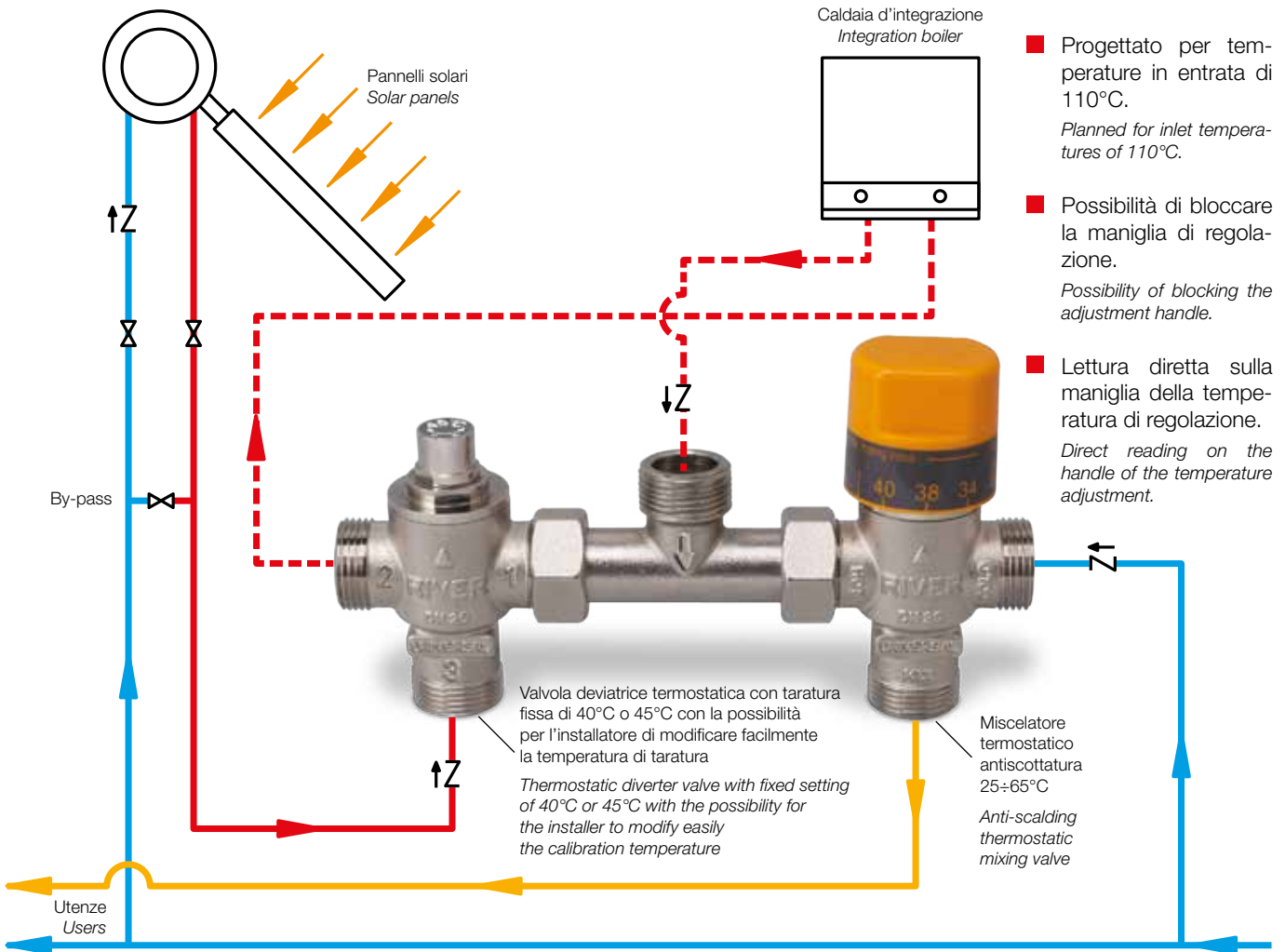

UNIVERSAL

KIT TERMOSTATICO Ø 3/4" - 1"
THERMOSTATIC KIT Ø 3/4" - 1"

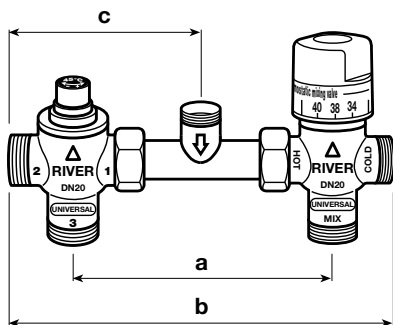

CODICE	Ø	mm a	mm b	mm c	NOTE
R 00482	3/4"	135	198	99	Kit universale termostatico per il collegamento del pannello solare alla caldaia di integrazione - massima temperatura entrata 110°C - valvola termostatica a 3 vie con la temperatura pre-tarata a 40°C - possibilità per l'installatore di modificare la taratura - portata a 3 bar 54 litri/minuto <i>Universal thermostatic kit for the connection of the solar panel to the integration boiler - maximum inlet temperature 110°C - 3-way thermostatic valve with temperature preset at 40°C - possibility to modify the temperature from the installer - flow rate 54 l/min. at 3 bar</i>
R 00483	3/4"	135	198	99	Idem 45°C Ditto 45°C
R 00487	1"	197	300	151	Idem 40°C Ditto 40°C
R 00488	1"	197	300	151	Idem 45°C Ditto 45°C