

ORINATOIO ELETTRONICO

A BARRIERA

INFRARED WALK-THROUGH URINAL

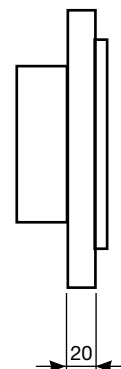
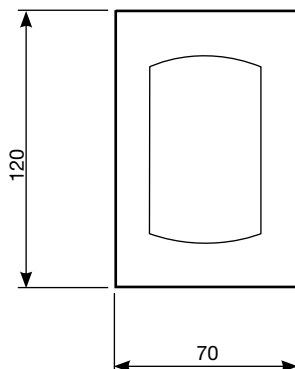

- Distanza 50-70 cm. dagli apparecchi (vedi disegno) – erogazione per circa 10 sec. - Protezione IP65
Distance 50-70cm. from the appliances (see drawing) - water supply for about 10 sec. IP65 protection

Trasformatore in scatola stagna
Transformer in watertight box
 230V - 12V

Dispositivo elettronico
Infrared device

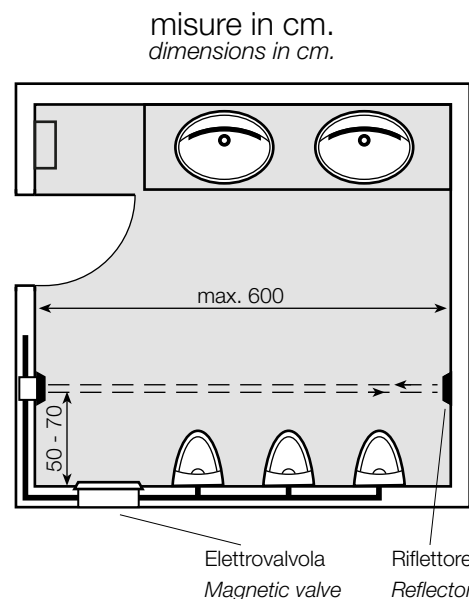

- L'impianto elettrico deve essere eseguito da personale abilitato
The electrical system must be performed by qualified personal

ORINATOIO ELETTRONICO A BARRIERA

INFRARED WALK-THROUGH URINAL

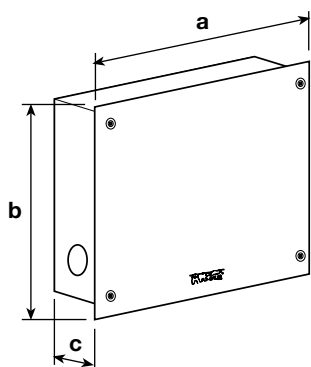

CODICE	mm a	mm b	mm c	NOTE
E2077/3	240	190	80	<p>Orinatoio a barriera da incasso elettronico con riflettore – alimentazione a rete 12Vdc – portata litri/minuto 70 a 3 bar – incorporato rubinetto Ø 1/2" con filtro inox per eventuale manutenzione 2 scatole per il montaggio:</p> <ul style="list-style-type: none"> ■ scatola n. 1 da incasso prof. 80 mm. con premontati rubinetto di chiusura, filtro inox ed elettrovalvola con chiusura progressiva ■ scatola n. 2 dispositivo elettronico mm. 120x70x20 e riflettore Ø 80. <p><i>Infrared walk-through built-in urinal with reflector - 12Vdc mains power supply - flow rate 70 liters/minute at 3 bar - built-in tap Ø1/2" with stainless steel filter for any maintenance 2 boxes for assembly:</i></p> <ul style="list-style-type: none"> ■ box n. 1 built-in prof. 80 mm. with pre-assembled faucet closure, stainless steel filter and solenoid valve with progressive closure ■ box n. 2 electronic device 120x70x20 mm and reflector Ø 80.